

Paper Roll Clamps Model TRA-N



The Bolzoni Auramo TRA-N tilting and rotating paper roll clamps are designed for vertical and horizontal handling of single paper rolls. They are an ideal solution for sideloading and unloading of horizontally positioned paper rolls from trailers, trucks and wagons.

90-degree forward tilt with built-in check-valve enables safe and efficient lifting of the horizontal paper rolls.

180-degree fast rotation with hydraulic cushioning in the vertical positions enhances the handling efficiency and flexibility.

Pivoting arm design offers a wide roll diameter range. The clamp has a short and a long arm. The short arm is hydraulically positionable to increase the roll range. The long arm is the clamping arm.

A wide selection of accessories, as well as several mounting and contact pad options are available.



Tilting and Rotating Paper Roll Clamps Models TRA-N

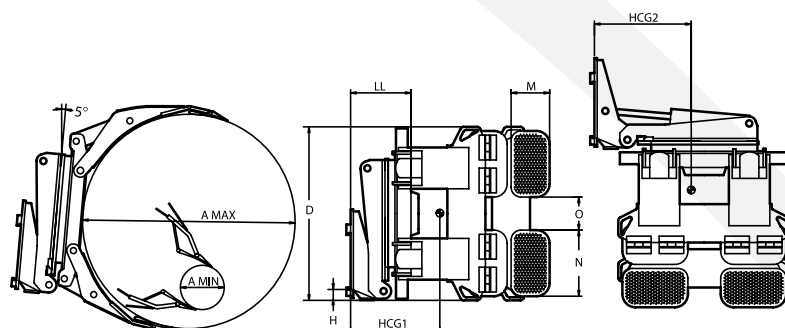

- Tilting and rotating paper roll clamp for vertical and horizontal roll handling.
- Pivoting arm movement. Short and long arms. Several different arm and contact pad options in standard series.
- 90-degree tilt with built-in check-valve.
- Thin-arm-profile design ensures tight stacking and effective damage-free handling with excellent visibility.
- 180-degree rotation, with hydraulic cushioning in the vertical positions.

| Model | Capacity | | Roll Range | Height | Weight | Horizontal Centre of Gravity | Vertical Centre of Gravity | Effective Thickness | Contact Pads | Contact Pad Gap | Mounting Height | Mounting Class |
|------------|----------|----------------------------|------------|--------|--------|---------------------------------|-------------------------------|------------------------|--------------|--------------------|--------------------|-------------------|
| | Q kg | BP1/BP2 mm ^① | | | | | | | | | | |
| TRA-220-N | 2200 | 650 /1200 | 250-1300 | 1040 | 1060 | 390/635 | ④ | 430 | 240x400 | 200 | 80 | 2A/3A |
| TRA-230-N | 2300 | 900 /1200 | 250-1800 | 1040 | 1100 | 435/635 | ④ | 430 | 240x400 | 200 | 80 | 2A/3A |
| TRA-250-N | 2500 | 800 /1200 | 250-1600 | 1040 | 1080 | 415/635 | ④ | 430 | 240x400 | 200 | 80 | 2A/3A |
| TRA-300-N | 3000 | 650 /1200 | 250-1300 | 1040 | 1060 | 390/635 | ④ | 430 | 240x400 | 200 | 80 | 2A/3A |
| TRA-280-N | 2800 | 915 /1300 | 250-1830 | 1240 | 1540 | 445/730 | ④ | 460 | 280x500 | 200 | 80 | 3A/4A |
| TRA-320-N | 3200 | 800 /1300 | 250-1600 | 1240 | 1520 | 430/725 | ④ | 460 | 280x500 | 200 | 80 | 3A/4A |
| TRA-350-N | 3500 | 650 /1300 | 250-1300 | 1240 | 1500 | 415/725 | ④ | 460 | 280x500 | 200 | 80 | 3A/4A |
| TRA-350-NL | 3500 | 800 /1300 | 250-1600 | 1240 | 1625 | 455/720 | ④ | 490 | 280x500 | 200 | 80 | 4A |
| TRA-380-N | 3800 | 915 /1300 | 300-1830 | 1240 | 1655 | 470/725 | ④ | 490 | 280x500 | 200 | 80 | 4A |
| TRA-400-N | 4000 | 800 /1300 | 250-1600 | 1240 | 1625 | 455/720 | ④ | 490 | 280x500 | 200 | 80 | 4A |
| TRA-450-N | 4500 | 650 /1300 | 250-1300 | 1240 | 1595 | 440/720 | ④ | 490 | 280x500 | 200 | 80 | 4A |

Three hydraulic functions. Special roll ranges on request. Consult Bolzoni Auramo for hydraulic pressure and flow rate recommendations.

Standard contact pads: cast pad with high-friction surface. Contact pad options: steel-sprayed surface, polyurethane-faced, rubber-faced or flexible. Full-length contact pads available on short arm side.

- ① Load centre is rated in the vertical and horizontal tilted positions.
- ② Minimum roll range in the horizontal tilted position is greater. Consult Bolzoni Auramo.
- ③ Horizontal centre of gravity is indicated in the vertical position and in the horizontal tilted position.
- ④ Consult Bolzoni Auramo regarding factory specifications.